



# Performance Handicap Racing Fleet

-

## Narragansett Bay (PHRF-NB)

Regulations - 20242025

# PHRF-NB Regulations

~~2024~~2025

## Table of Contents

1. Preface.....	4
2. Administration.....	4
3. Committee Members.....	4
4. Definitions.....	5
4.1 Yacht:.....	5
4.2 Boat Measurements:.....	5
4.3 Sails.....	7
4.4 Variables.....	7
5. Base Configuration.....	8
5.1. PHRF-NB considers the base boat to be as follows:.....	8
a. Genoa/Jib -.....	8
b. Spinnakers.....	8
c. Mainsails.....	8
d. Propeller.....	8
f. Base Boat Rating – The Base Rating will take into account standard rig measurements (I, J, P, E), sail.....	8
6. Sails.....	8
6.1. Mainsails.....	8
a. Standard.....	8
b. Oversize Girths.....	8
c. Limits.....	8
d. Undersize Girths.....	9
e. Mainsail Adjustment Table.....	9
f. Substantial changes to the sail profile, or area changes in excess of $\pm 20\%$ .....	10
6.2. Headsails.....	10
a. Luff:.....	10
b. Mid Girths:.....	10
c. Roller Furler Credit (+3).....	12
d. Cruising Headsail Credit (+3).....	12

6.3.	Spinnakers.....	13
a.	Symmetrical Spinnakers.....	13
b.	Asymmetric Spinnakers:.....	13
c.	General .....	13
d.	Oversize (SPL) (SPL/Lu) (Area).....	14
e.	Asymmetric Spinnaker Conversions.....	15
6.4.	Flying Headsails.....	16
6.5.	Non-Spinnaker Adjustments .....	16
7.	Hull/Mechanicals .....	17
7.1.	Engine .....	17
7.2.	Length Waterline Changes .....	18
7.3.	Displacement Changes .....	18
7.4.	Keel Type Changes / Modifications .....	18
7.5.	Draft Changes .....	18
7.6.	Water Ballast .....	18
8.	Modifications.....	18
8.4.	Reportable Modifications .....	18
8.5.	Non-Reportable Modifications.....	20
	Appendix A - Spinnakers adjustment based on the boat configuration.....	21

# PHRF-NB Regulations - ~~2024~~2025

## 1. Preface

PHRF-NB strives to consistently provide fair ratings for dissimilar boats to race against each other. The best use of these ratings is done by grouping boats in the smallest rating band with like type boats. It is expected that all designs will have preferred conditions and may excel when those are met. The challenge we face is to balance the rating to the local predominate condition in an effort to have the best sailed and prepared boats finish in the top third. The Rating Committee (RC) reviews race results on a regular basis. This is typically done with at least a years' worth of results for a boat type to determine whether ratings need to be adjusted.

## 2. Administration

PHRF performance handicaps are boat performance handicaps based on the speed potential of the boat determined, as far as possible, by observations of race results, VPP data, and ratings from other Rating Systems. The intent of PHRF handicapping is that any well-equipped, well-maintained and well-sailed boat has a good chance to win; and any boat that wins a PHRF race is indeed well-equipped, well-maintained, and well-sailed. Handicaps are adjusted, as needed, on the basis of the boat's performance so that each boat will have an equal opportunity to win. This is the fundamental concept.

PHRF-NB ratings are set by the Rating Committee (RC). The RC reviews boat data, race results and boat modifications to name a few to determine a boats rating. We, PHRF-NB, will initially set a boats 'base handicap' and then apply adjustments for modifications. For a new boat to PHRF-NB, the RC will look for a boat as similar as possible to the boat being rated, consider VPP data and other PHRF regions/ratings systems to establish a "Provisional Rating". After a year of racing results, which can be reviewed, the RC will adjust as necessary and issue the Rating Certificate. In this way, if/when a sister ship requests a rating the process is to apply adjustments for the particular boat's modifications. The RC encourages all applicants to provide as much and as accurate data as possible. Including all reported sail measurements (Main sail, Largest Jib/Genoa, Largest Spinnaker and Code 0 or Reaching Headsail).

## 3. Committee Members

The names of the committee members are listed on the PHRF-NB website <http://phrf-nb.org/node/6793> along with the administrators contact information. The committee members are all committed to keeping ratings accurate. I encourage you to contact Administrator with questions or concerns who will direct the inquiries to the appropriate member. They are all involved because they want to make a difference and promote a sport they enjoy.

## 4)4. Definitions

### 4.1 Yacht:

<b>Yacht Name</b>	Name of boat, e.g. "Clara"
<b>Sail #</b>	Number displayed on your sails
<b>Designer</b>	Yacht designer
<b>MFCTR</b>	Yacht Manufacturer
<b>Model</b>	C&C 35-2, for a custom boat (designer): CTM Farr 45'.
<b>Hull ID #</b>	Hull Identification Number (HIN) located on starboard corner of transom.
<b>Date MFD</b>	Date of manufacture of model year, if known.
<b>Other Ratings</b>	Indicate a PHRF rating received from another area, e.g. NE-PHRF Base 72; IMS GP 622; ORA-1 Base 90.

### 4.2 Boat Measurements:

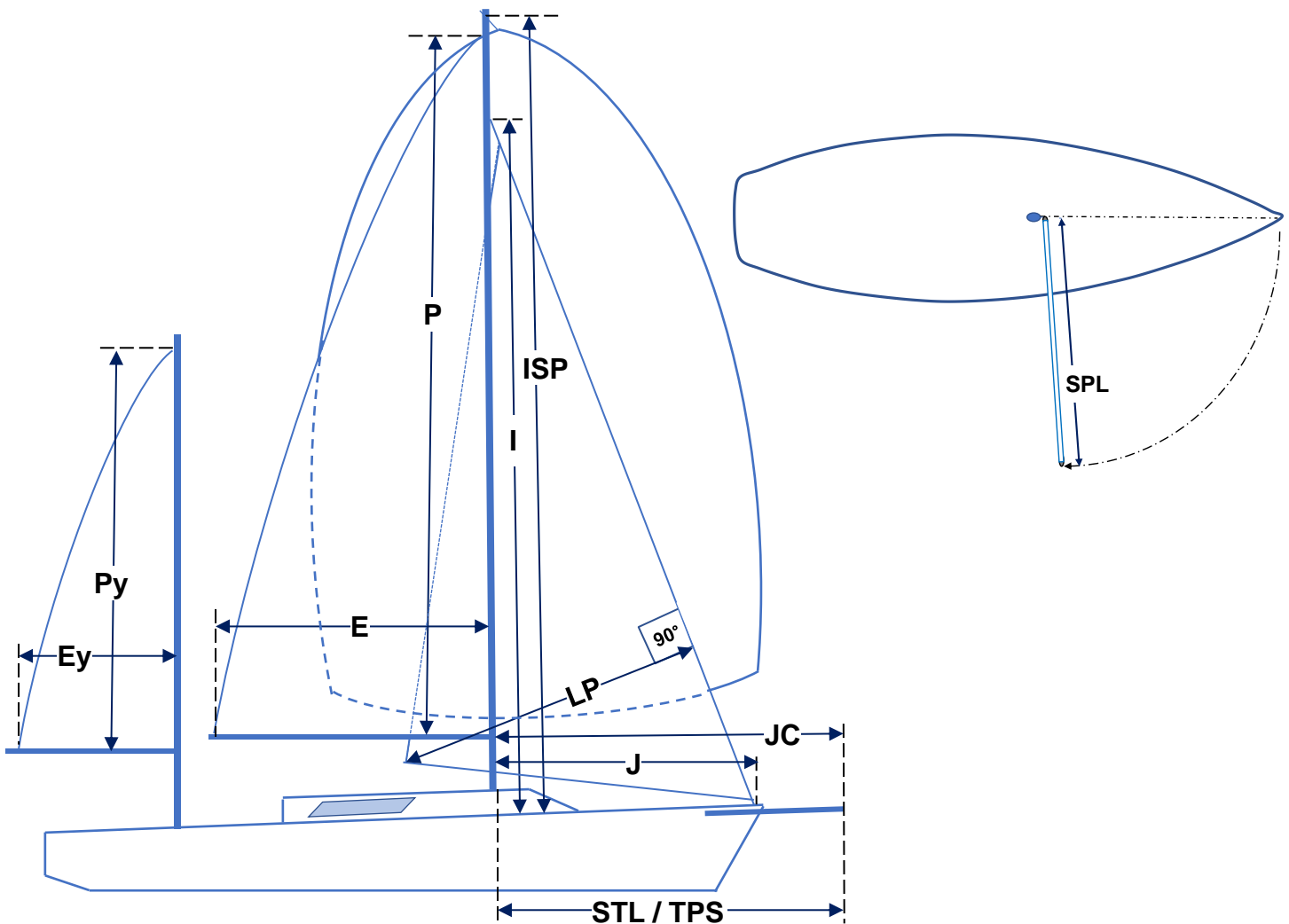

- I** Dimension measured from the sheer line at the mast to the maximum hoist of the jib/genoa.
- J** Distance from the forward side of the mast to the intersection of the headstay and deck.
- JC STL/TPS** On boats with asymmetrical spinnaker tacked forward of the headstay (anchor roller, bowsprit or similar) distance from the headstay/deck intersection forward to the tack location for the spinnaker, added to the J dimension. On boats with

	articulating bowsprits this measurement should be with the sprit parallel with the fore/aft centerline of the boat.
<b>P</b>	Mainsail luff length from the top of the boom to the bottom of the upper mast band. If no band, to the top of the main halyard sheave.
<b>Py/P2</b>	Mizzen luff length from the top of the boom to the top of the headboard with the sail fully hoisted.
<b>E</b>	Foot length of the mainsail from the aft face of the mast to the inboard edge of the band boom. If no black band, to the clew in its most outboard position.
<b>Ey/E2</b>	Foot length of the mizzen sail from the aft face of the mast to inboard edge of black band on boom.
<b>ISP</b>	Distance from the sheer line at the mast to the maximum hoist of the spinnaker.
<b>SPL</b>	Spinnaker/whisker pole length is measured from the center line of the mast (fore side) to the extreme outboard end of the fitting with the spinnaker/whisker pole in its mast fitting and set in a horizontal, athwart-ship position.
<b>LOA</b>	Length overall of hull, should not include bowsprits or boomkins.
<b>LWL</b>	Length waterline, if unmeasured use the brochure/published dimension.
<b>Max Draft</b>	Maximum depth of vessel measured without crew, water, fuel or stores. If un-measured use the brochure/published dimension. For centerboard yachts, report "board up" drafts.
<b>Beam</b>	Maximum width of vessel
<b>Displacement</b>	(DISP) Weight of water displaced by vessel without crew, water, fuel or stores. If unmeasured use the brochure/published value.
<b>Ballast</b>	(BAL) Weight of ballast in pounds. Note any deletions with amount and location.
<b>Rig Type</b>	The sail plan configuration (sloop, yawl, ketch, cutter, Cat, etc.)
<b>Rig</b>	Either masthead or fractional referring to the location of the headstay on the mast.
<b>Keel Weight</b>	Weight of keel in pounds if known.
<b>Keel Material</b>	Lead, Cast Iron, etc.
<b>Composite Rigging</b>	Defined as synthetic rigging used to support the mast laterally and as a headstay. Composite backstays, runners or check stays are not included.
<b>Other Ballast</b>	Note any additional ballast with amount and location, such as bilge ballast or corrector weights. If Port & Stb'd water ballast, total gallons on one side.
<b>Mast material</b>	Aluminum, wood, carbon, etc.
<b>Spinnaker Types</b>	Identifies types of spinnakers to be used, symmetric and/or asymmetric.
<b>Asymmetric Spinnaker</b>	
<b>Tacked to:</b>	Location asymmetric spinnaker is attached to boat, for example anchor roller, bow sprit, spinnaker pole etc.
<b>Code Zero</b>	A spinnaker designed for reaching that is typically just over the 75% mid-girth requirement.

**Flying Headsails** (Reaching Headsails): ~~(Flying Headsails)~~

A sail that is not attached to the headstay and sail that does not conform to having a SMG  $\geq$  75% of the foot length.

### 4.3 Sails

<b>LP</b>	Luff Perpendicular. Measurement from the Headsail Clew to a point perpendicular to the Luff. For purposes of adjustment this is represented as a percentage of the J dimension.
<b>MHB</b>	Mainsail headboard or Square top width.
<b>MUW/MGT</b>	Mainsail girth from $\frac{7}{8}$ leech to nearest point on mainsail luff.
<b>MTW/MGU</b>	Mainsail girth from $\frac{3}{4}$ leech to nearest point on mainsail luff.
<b>MHW/MGM</b>	Mainsail girth from $\frac{1}{2}$ leech to nearest point on mainsail luff.
<b>MQW/MGL</b>	Mainsail girth from $\frac{1}{4}$ leech to nearest point on mainsail luff.
<b>ALU/SLU</b>	Length of Asymmetrical/Symmetrical luff from head to tack.
<b>ALE/SLE</b>	Length of Asymmetrical/Symmetrical leech from head to clew.
<b>AF/SFL</b>	Length of Asymmetrical/Symmetrical foot from clew to tack.
<b>AMG/SMG/AMU/SMU/SHW</b>	Asymmetrical/Symmetrical spinnaker girth from $\frac{1}{2}$ luff to $\frac{1}{2}$ leech.
<b>Headsail Credit</b>	Refer to requirements <a href="#">Roller Furler</a> or <a href="#">Cruising Headsail</a>

### 4.4 Variables

It is assumed that the boat has a means of auxiliary propulsion. This is included in each boat's base rating. We also assume that the boat either has an outboard engine that may be stowed below while racing or an inboard engine fitted with a folding/feathering propeller. Adjustments from this can be found in [Table I](#).

<b>Engine</b>	Inboard or outboard
<b># of Blades</b>	2 or 3 or 4 blades
<b>Prop Type</b>	Refers to the type of propeller, fixed, folding, feathering
<b>Prop Install</b>	How is the propeller installed, aperture, exposed shaft, sail drive, thru Keel, drop box, etc.
<b>Note:</b>	<p>"Aperture" is where the propeller is located in a faired opening between full keel and attached rudder</p> <p>"Thru Keel" is where the propeller shaft exits from the trailing edge of the keel.</p>
<b>Rudder</b>	Type of installation, <del>e.g. spade, and keel</del> <a href="#">Keel</a> , <a href="#">skeg</a> <a href="#">Skeg</a> , <a href="#">Spade</a> , <a href="#">Transom (outboard)</a> and <a href="#">Twin-</a>
<b>Keel Type</b>	<del>Fin, bulb/strut, full, canting, bilge, centerboard, winged, etc.</del> <a href="#">Canting (CTK)</a> , <a href="#">Centerboard (CB)</a> , <a href="#">Centerboard/Keel (CK)</a> , <a href="#">Daggerboard (DB)</a> , <a href="#">Fin (FK)</a> , <a href="#">Full (FLK)</a> , <a href="#">Lifting (LK)</a> , <a href="#">Strut/Bulb (SBK)</a> , <a href="#">Swing (SWK)</a> , <a href="#">Twin (TK)</a> , and <a href="#">Wing (WK)</a>

## 5. Base Configuration

### 5.1. PHRF-NB considers the base boat to be as follows:

- a. **Genoa/Jib** - This is determined by looking at the original design. If a boat was originally designed with overlapping genoas, we set the base rating for the design with a 155% genoa. Adjustments for varied sail sizes are then based on this.
  - i. If a boat is designed with non-overlapping headsails (jibs) we set the base rating on this (<118%). These boats will typically have the side shroud chain plates attached at the hull deck joint.
  - ii. The RC will make this determination when the base rating is established and it will be noted in our base rating database.
- b. **Spinnakers** - It is assumed the boat has a spinnaker. We will review sail plans, design literature and drawings to determine the type when a base rating is determined. Details of measurements can be found in [section 6.3](#).
- c. **Mainsails** – It is assumed that the mainsail conforms to the original design or Maximum Girths as described in [6.1.a.-c](#).
- d. **Propeller** - It is assumed in the base rating that the boat has either a folding propeller on an exposed shaft or sail drive or an outboard. Vessels not equipped with one of the configurations will have an adjustment applied to their rating.
- e. **Displacement** – We acknowledge that this is a grey area as many designs are delivered well outside of the ‘listed displacement’. Despite this we will use the listed displacement as the basis for base ratings.
- f. **Base Boat Rating** – The Base Rating will take into account standard rig measurements (I, J, P, E), sail sizes/areas, displacement as the boat was designed or from original OD Class information. Variations shall be reported to the Rating Committee. If the excursion(s) is deemed significant, a PHRF-NB base rating will be issued, which notes the modification(s). **To summarize** - We assume the boat is in all respects, as delivered from the original manufacturer. Any change to the original manufacturer design or specification not covered in these rules shall be reported and subjected to a review for possible adjustment.

## 6. Sails

### 6.1. Mainsails

- a. **Standard** – ORC maximum girths or as designed and rated originally.
- b. **Oversize Girths** - For mainsails whose girths are greater than ORC standards, greater than original design, greater than class rules, or for a change in size, ratings will be adjusted as follows: (% increase is the sail area increase based on the following formula:

$$Area = \frac{P}{8} (E + 2 \cdot MQW + 2 \cdot MHW + 1.5 \cdot MTW + MUW + 0.5 \cdot MHB)$$

- c. **Limits** - The following limits apply for mainsails based on ORC:



**ORC Mainsail Maximum Girths**

- MHB (Headboard/Square top) = 0.065 x E
- MUW (Girth at 7/8 leach) = 0.22 x E
- MTW (Girth at 3/4 leach) = 0.38 x E
- MHW (Girth at 1/2 leach) = 0.65 x E
- MQW (Girth at 1/4 leach) = 0.90 x E

**Adjustments**

<b><u>% Increase</u></b>	<b><u>Adjustment Sec/mile</u></b>
<del>1% to 4%</del>	<del>1</del>
<del>4.1 to 8%</del>	<del>2</del>
<del>8.1 to 12%</del>	<del>3</del>
<del>12.1 to 16%</del>	<del>4</del>
<del>16.1 to 20%</del>	<del>5</del>
<del>etc.,</del>	

**d. Undersize Girths** - For mainsails whose girths are less than ORC standards, less than original design, less than class rules, or for a change in size, ratings will be adjusted based on the above formula [\(6.1.b.\)](#):

**i. Adjustment** - This adjustment will not be applied unless measurements are supplied with the Certificate information

**ie. Mainsail Adjustment Table**

<b>Mainsail Area Adjustment</b>		
<b>% Change</b>		<b>Sec/knm</b>
16.10%	20.00%	-5
12.10%	16.00%	-4
8.10%	12.00%	-3
4.10%	8.00%	-2
0.10%	4.00%	-1
0.10%	-2.00%	0
-2.10%	-4.00%	+1
-4.10%	-8.00%	+2
-8.10%	-12.00%	+3
-12.10%	-16.00%	+4
-16.10%	-20.00%	+5

**Adjustments**

<b><u>% Decrease</u></b>	<b><u>Adjustment Sec/mile</u></b>
2.0% to 4%	+1
4.1 to 8%	+2
8.1 to 12%	+3
12.1 to 16%	+4

~~16.1 to 20%~~ + 5  
~~etc.,~~

**e.f. Substantial changes to the sail profile, or area changes in excess of ±20%**

Regardless of Area, substantial changes to the sail profile and excessive area changes shall be reviewed by the Committee for possible adjustment.

## 6.2. Headsails

**a. Luff:**

The luff of a headsail shall be attached to the headstay.

**b. Mid Girths:**

LP  $\geq$  118.1 – midgirth shall be  $<50\%$  of sails measured foot

LP  $<$  118.1 – midgirth shall be  $<55\%$  of sails measured foot

For boats with a 155% headsail as base refer to Table A for adjustment

For boats with a  $<118\%$  headsail as base refer to [Table B](#) for adjustment.

**Table A: 155% Headsail Base**

LP% Lower Limit	LP% Upper Limit	Spinnaker Adjustment	Non-Spinnaker Adjustment
167.1	170	-5	-5
164.1	167	-4	-4
161.1	164	-3	-3
158.1	161	-2	-2
155.1	158	-1	-1
151.1	155	0	0
148.1	151	1	1
145.1	148	2	2
142.1	145	3	3
139.1	142	4	4
136.1	139	5	5
133.1	136	6	6
130.1	133	7	7
127.1	130	8	8
124.1	127	9	9
121.1	124	9	10
118.1	121	9	11
Less than 118%	118	9	12

**Table B:  $<118\%$  Headsail as Base**

<b>LP% Lower Limit</b>	<b>LP% Upper Limit</b>	<b>Spinnaker Adjustment</b>	<b>Non-Spinnaker Adjustment</b>
167.1	170	-14	-17
164.1	167	-13	-16
161.1	164	-12	-15
158.1	161	-11	-14
155.1	158	-10	-13
151.1	155	-9	-12
148.1	151	-8	-11
145.1	148	-7	-10
142.1	145	-6	-9
139.1	142	-5	-8
136.1	139	-4	-7
133.1	136	-3	-6
130.1	133	-2	-5
127.1	130	-1	-4
124.1	127	0	-3
121.1	124	0	-2
118.1	121	0	-1
Less than 118%	118	0	0

**c. Roller Furler Credit (+3)**

Class Boats or a custom boat equipped by the original manufacturer with a roller furler, upon which the base boat handicap is established, are **not** eligible for a roller furl credit.

Headsails shall comply with the following:

- i. All sails to be used shall have a luff length 2.5% of the “I” measurement shorter than the head stay length as measured from the deck sheer line to the mast intersection.
- ii. Furler bottom drum mounted above the deck.
- iii. The sail shall be attached to the bottom drum, hoisted in a foil extrusion and have a top swivel, the system shall be functional.
- iv. The sail shall be furled when not in use and racing.

**OR**

**d. Cruising Headsail Credit (+63)**

Cruising Headsails shall comply with the following:

- i. The cruising headsail shall have a luff length 2.5% of the “I” measurement shorter than the head stay length as measured from the deck sheer line to the mast intersection.
- ii. The cruising headsail shall be attached to the bottom drum, hoisted in a foil extrusion and have a top swivel, the system shall be functional.
- iii. The cruising headsail is the primary headsail used on the boat. Any additional headsails used must be less than 110% LP. The cruising headsail is stored on the head stay when not racing.
- iv. The cruising headsail has a UV leach cover attached to the sail (e.g. stitched or glued).
- v. Sail’s material must be: Woven Polyester, Polyester Composite or Polyester laminate, with an additional layer of woven polyester (taffeta), or Composite skin, both with the intent of adding durability to the sail. Exotic materials are not allowed; (Pentex, PEN, Aramid, Technora, Carbon, Spectra, Ultra-PE).
- vi. The cruising headsail is regularly used as the primary genoa/headsail when the boat is racing, day sailing or cruising and will be the only PHRF-NB certificate issued during the sailing season.

## 6.3. Spinnakers

### a. Symmetrical Spinnakers

- i. Maximum Standard luff length shall be not greater than  $.95 * \sqrt{(ISP^2+SPL^2)}$
- ii. Maximum Standard foot length and Mid-Girth shall be not greater than  $1.8 * SPL$
- iii. Any change in STL not accompanied with a commiserate change in SMG shall be reviewed by the Committee for possible further adjustments not covered within these rules. Owners are advised to consult with the Committee before making such a change.
- iv. Any change in ISP not accompanied with a commiserate change in AREA shall be reviewed by the Committee for possible further adjustments not covered within these rules. Owners are advised to consult with the Committee before making such a change.

### b. Asymmetric Spinnakers:

Asymmetric Spinnakers shall comply with the following requirements:

- i. Maximum Standard luff length shall be  $\leq 110\% * \sqrt{(ISP^2+STL^2)}$
- ii. Maximum Standard SMG shall be  $\leq 1.8 * STL$
- iii. SMG shall be  $\geq 75\%$  of foot length.
- iv. Boats articulating the tack of an asymmetric spinnaker shall indicate this on their application.
- v. Any change in STL not accompanied with a commiserate change in SMG shall be reviewed by the Committee for possible further adjustments not covered within these rules. Owners are advised to consult with the Committee before making such a change.
- vi. Any change in ISP not accompanied with a commiserate change in AREA shall be reviewed by the Committee for possible further adjustments not covered within these rules. Owners are advised to consult with the Committee before making such a change.

### c. General

- i. Boats using both symmetric and asymmetric spinnakers from a standard spinnaker pole shall indicate this on their application. Spinnaker staysails shall be allowed when using a boats spinnaker rating.
- ii. All sails classified as spinnakers shall be passed forward of the headstay during tacking and gybing maneuvers. A Code 0 is a spinnaker.
- iii. [Appendix A](#) references how spinnakers are adjusted based on the boat configuration.
- iv. [Appendix B](#) is an open list of **Boats with Standard Asymmetrical Spinnaker Areas**

**d. Oversize (SPL) (SPL/Lu) (Area)**

- i. Oversized Symmetric spinnakers will be adjusted based on [Table C](#). Oversized Asymmetric spinnakers will be adjusted based on [Table D](#).
  - a.) Area used to compare larger or smaller size spinnakers shall be calculated with the standard IRC Spinnaker Area Formula:
    - i.)  $SPA = ((SLU + SLE)/2) * ((SFL + (4 * SHW))/5) * 0.83$   
 SLU, SLE, SFL and SHW of the largest area spinnaker on board shall be declared.
    - ii.) This formula shall apply to either Symmetrical or Asymmetrical spinnakers. (Unless otherwise defined in this document)
    - iii.) If a boat has a Class, Designer or Regional Area that shall govern.
  - ii. For boats that were designed originally with Symmetric Spinnakers, the Standard SMG and SFL is based on  $SPL * 1.8$  and MAX LUFF based on  $.95 * \sqrt{(ISP^2 + STL^2)}$  with all other dimensions entered into the above Area Formula (SPA) to determine the **Standard Symmetric Spinnaker Area**, unless there is an OD, designer or regional standard for the boat. Any changes to the Spinnaker Area will be adjusted based on [Table C](#).
  - iii. For Boats that were designed originally with asymmetric spinnakers (but not having a controlling reference 6.3.d.i.a.)iii.) (above) the Formula used to compute the **Standard Asymmetric Spinnaker Area** shall be  $(ISP * STL * 1.8 * .83)$ . Adjustments to the Base rating will then be based on [Table D](#).
    - a.) If a boat's **Performance Factor** exceeds 3.5 based on the formula:  $[(.67 * LWL) + (.34 * LOA)] * (SA / DISP)$  where  $SA = (((STL * ISP) + (P * E)) / 2)$  the **Standard Asymmetric Spinnaker Area** shall be  $(ISP * STL * 1.8 * .73)$ .
- iv. **Undersized Area** will not be adjusted unless measurements are supplied with the Certificate.

**Table C: Symmetrical Spinnaker**

(Area)	Sec/Mile Adjustment	(Area)	Sec/Mile Adjustment
<90%	7	>127% to 130%	-10
>=90% to 93%	5	>130% to 133%	-11
>93% to 96%	3	>133% to 136%	-12
>96% to 100%	0	>136% to 139%	-13
>100% to 103%	-1	>139% to 142%	-14
>103% to 106%	-2	>142% to 145%	-15
>106% to 109%	-3	>145% to 148%	-16
>109% to 112.0%	-4	>148% to 151%	-17
>112% to 115%	-5	>151% to 154%	-18
>115% to 118%	-6	>154% to 157%	-19
>118% to 121%	-7	>157% to 160%	-20
>121% to 124%	-8	>160% to 163%	-21
>124% to 127%	-9	Etc.	Etc.

**Table D: Asymmetrical Spinnaker**

(Area)	Sec/Mile Adjustment	(Area)	Sec/Mile Adjustment
<75%	12	>128% to 133%	-7
>=75% to 80%	9	>133% to 138%	-8
>80% to 85%	7	>138% to 143%	-10
>85% to 90%	4	>143% to 145%	-11
>90% to 94%	2	>145% to 147%	-12
>94% to 100%	0	>147% to 149%	-13
>100% to 101%	-1	>149% to 151%	-14
>101% to 109%	-2	>151% to 153%	-15
>109% to 118%	-3	>153% to 155%	-16
18% to 123%	-4	>155% to 157%	-18
>123% to 128%	-6	Etc.	Etc.

**e. Asymmetric Spinnaker Conversions**

Boats converting from symmetrical to asymmetrical spinnakers will be adjusted as follows below.

- i. For boats that were designed originally with Symmetric Spinnakers that have converted over to an Asymmetric on centerline, the Standard Spinnaker Area for the boat shall be the Standard Symmetric Spinnaker Area. Adjustments to the Base rating will then be based on [Table D](#) and [Table E](#).
- ii. Boats with the sail tacked to the bow, on centerline, without also using an articulating pole/symmetrical spinnaker pole will receive between 2 and 14 sec/mile credit. This will be based on the formula below.
  - a.)  $\text{Downwind SA} = \text{Mainsail Area} + \text{Spinnaker Area} (\text{ISP} \times (\text{J} \times 1.8)) / 2$ 
    - i.) Mainsail Area shall be the larger of the Areas between the formula in [6.1.b](#). or  $(P \times E \times .585)$
    - ii.) Spinnaker Area as applicable in [6.3.d. i.-iv](#).
  - b.)  $\text{Downwind SA-DISP} / \text{DISPL} - L$ . This Ratio is inputted into Table E below:

**Table E: Downwind Ratio Adjustment**

Ratio	Adjustment
< 0.1	14
>= 0.1 < 0.15	13
>= 0.15 < 0.2	12
>= 0.2 < 0.225	11
>= 0.225 < 0.275	9
>= 0.275 < 0.3	7
>= 0.3 < 0.35	6
>= 0.35 < 0.375	4
>= 0.375	2

## 6.4. ~~Reaching Headsails~~ (Flying Headsails)

### a. Reaching Headsails

a.i. These sails are defined as a sail that is not attached to the headstay (6.2.a.) and sail that does not conform to having a SMG  $\geq$  75% of the foot length (6.3.b.iii.).

b.ii. Sails in this class shall be subject to Table F below:

**Table F: Reaching Headsail Adjustment**

SMG/SFL Ratio	Sec/Mile Adjustment
70 to 74.99%	-2
65 to 69.99%	-3
60 to 64.99%	-4
55 to 59.99%	-5
50 to 54.99%	-7

b. Staysails, tallboys and bloopers are permitted in spinnaker class racing and will not exceed the sail area of the largest genoa rated.

## 6.1.6.5. Non-Spinnaker Adjustments

a. Compute mainsail to genoa sail area ratio with the following formula:

$$\frac{P * E}{I * J}$$

b. Apply ratio to the Table G below.

**Table G: Non-Spinnaker Adjustment**

Main/Genoa Ratio	Adjustment sec/mile	Main/Genoa Ratio	Adjustment sec/mile
.50 + - .60	24	1.7 + - 1.8	12
.60 + - .70	23	1.8 + - 1.9	11
.70 + - .80	22	1.9 + - 2.0	10
.80 + - .90	21	2.0 + - 2.2	9
.90 + - 1.0	20	2.2 + - 2.4	8
1.0 + - 1.1	19	2.4 + - 2.6	7
1.1 + - 1.2	18	2.6 + - 3.0	6
1.2 + - 1.3	17	3.0 + - 3.4	5
1.3 + - 1.4	16	3.4 + - 4.0	4
1.4 + - 1.5	15	4.0 + - 5.0	3
1.5 + - 1.6	14	5.0 + - 6.0	2
1.6 + - 1.7	13	6.0 + - 7.0	1
		> 7.0	0



- c. Whisker or spinnaker poles may be used to hold the clew of the headsail outboard. The poles length shall not exceed the SPL as shown on the rating certificate.
- d. Whisker poles shall be marked with a black band at the SPL
- e. Headsails shall be attached to a stay along the luff
- f. Only one headsail shall be used at a time with two exceptions:
- g. While changing headsails two sails may be raised for a short period of time
- h. Boats noted as cutter rigged on the certificate may fly a staysail. The inner fore stay shall remain rigged at all times. Note that 6.5.d. above applies to both sails.
- i. Spinnakers or free flying sails shall not be used during non-spinnaker racing.
- j. Whisker or Spinnaker poles which exceed rated SPL shall be subject to Table H below:

**Table H: Oversize Whisker/Spinnaker Poles for Non-Spinnaker**

SPL	SEC/MILE	SPL	SEC/MILE
Up to 101%	0	>111% to 114%	-4
>101% to 104%	-1	>114% to 117%	-5
>104% to 107%	-2	>>117% to 121%	-6
>107% to 111%	-3	Etc	

## 7. Hull/Mechanicals

### 7.1. Engine

It is assumed that the boat has a means of auxiliary propulsion. This is included in each boat's base rating. We also assume that the boat either has an outboard engine that may be stowed below while racing or an inboard engine fitted with a folding/feathering propeller. Adjustments from this are as follows in Table I below.

**Table I: Propeller Adjustment**

Position	# of Blades	Type of Propeller	Sec/Mile
Aperture	3	Solid	6
Aperture	2	Solid	3
Aperture	2 or 3	Feathering/Folding	-3
Exposed Shaft	2 or 3	Feathering/Folding	0
Exposed Shaft	2	Solid	6
Exposed Shaft	3	Solid	12
Sail Drive	2 or 3	Folding	0
Sail Drive	2 or 3	Solid	3
Sail Drive	3	Solid	6
Thru Hull	2 or 3	Feathering/Folding	0
Thru Hull	2	Solid	3
Thru Hull	3	Solid	6

<b>None/Insufficient</b>	---	---	<b>-3</b>
<b>Outboard (not in water)</b>	---	---	<b>0</b>
<b>Drop Box Propeller</b>	<b>2 or 3 or 4</b>	<b>Solid</b>	<b>Varied</b>

## 7.2. Length Waterline Changes

LWL changes will be reviewed by the committee on a case-by-case basis.

*Note that this typically implies significant changes to a boat. If you are interested in modifying your boat and believe a LWL adjustment is due, please contact PHRF-NB in advance to discuss.*

## 7.3. Displacement Changes

The typical adjustment for displacement modifications is based on 5 sec/mile for 10% of displacement. Rating adjustment based on equipment additions will not be considered until a minimum of a 10% change is made to the vessel's displacement. The committee will review all displacement adjustments on a case-by-case basis.

## 7.4. Keel Type Changes / Modifications

Keel type changes are typically reviewed as outlined below. They will be reviewed on a case-by-case basis.

- i. Shallow Draft – 6-12 sec/mile
- ii. Center board – 6-9 sec/mile
- iii. Iron vs Lead – 3 sec/mile
- iv. Dagger boards – 0 sec/mile
- v. Deep draft, wing, bulb/strut, canting, etc changes will be addressed individually by the Committee

## 7.5. Draft Changes

Draft changes are reviewed by the committee and typically are 3 sec/mile for each 0.5 ft. of change (+/-).

## 7.6. Water Ballast

Water ballast changes will be reviewed by the committee on a case-by-case basis. In general, the modification will be assessed a -1 sec/mile adjustment for every 1% of additional displacement.

# 8. Modifications

## 8.4. Reportable Modifications

- a. Any changes in material, size, or shape (other than fairing to original design specification) of the hull, deck, rudder, or keel.
- b. Any canard rudder, other lifting or steering device forward of the keel; or any rudder, steering or stabilizing device added to the boat.
- c. Any addition of a lifting, foiling device to the boat.
- d. Removal or relocation of any interior or exterior structural components; changes in construction technique/schedule, or changes in materials of bulkheads and or interior cabinetry, that results in the removal or relocation of weight.
- e. Removal or replacement of standard tables, floorboards, headliners, lockers, locker doors, permanent berths and head enclosures, i.e., you are not allowed to “strip the boat”.
- f. Removal or addition of any internal ballast of lead or similar density material. Any movable ballast, (i.e. water ballast): indicate weight, location, volume and rate of transfer if applicable.

- g. Any modification to rig dimension, i.e. increase/decrease in mast(s) height, boom(s) length or spinnaker pole length.
- h. Spinnaker or whisker poles and asymmetric spinnaker tack points exceeding 101% of J.
- i. Change in cross section, weight or material of mast(s) or boom(s).
- j. Addition or elimination of spreaders, shrouds or stays including running backstays, baby stays, check stays, jumper struts or installation of split backstays.
- k. Use of cobalt, boron, titanium, or carbon fiber in rigs, lifelines or lifeline stanchions.
- l. Use of fixed or adjustable bowsprit for flying spinnakers.
- m. Changing headstays, stays or shrouds to carbon, PBO or other composite materials
- n. Changing location of headstays, stays or shrouds.
- o. Headstays, mast stays, mast bases and or partners that are adjustable while racing, whether accomplished mechanically or hydraulically.
- p. Use of hiking straps, trapeze wires, or similar devices that would allow the torsos of the crew or skipper to be extended beyond the beam of the boat.
- q. All sails, new to the boat, that change the rated sail area, shall be reported and the application shall be accompanied with a sailmaker's certificate.

## 8.5. Non-Reportable Modifications

- a. Removal of cushions is permitted.
- b. Changing material used for backstay.
- c. Fairing to bring the hull, keel or rudder into design specifications. Wet sanding and/or waxing are allowed.
- d. Flexible flaps to fair the skeg into the rudder are allowed provided they do not extend deeper than the skeg.
- e. Water, fuel, and holding tanks maybe emptied as provided by US SAILING.
- f. Removal, addition and/or relocation of deck hardware.
- g. Running rigging of any size or material.
- h. There are no restrictions on instruments electronic or mechanical, autopilots, and on-board computers except that outside information may be received only as permitted by US SAILING.
- i. Use of full battens in mainsail.
- j. There are no restrictions on type of material or construction technique except as outlined in 6d and for the Cruising Headsail credit above.
- k. Any number of storm jibs (LP less than 95%) can be used.

# Appendix A - Spinnakers adjustment based on the boat configuration

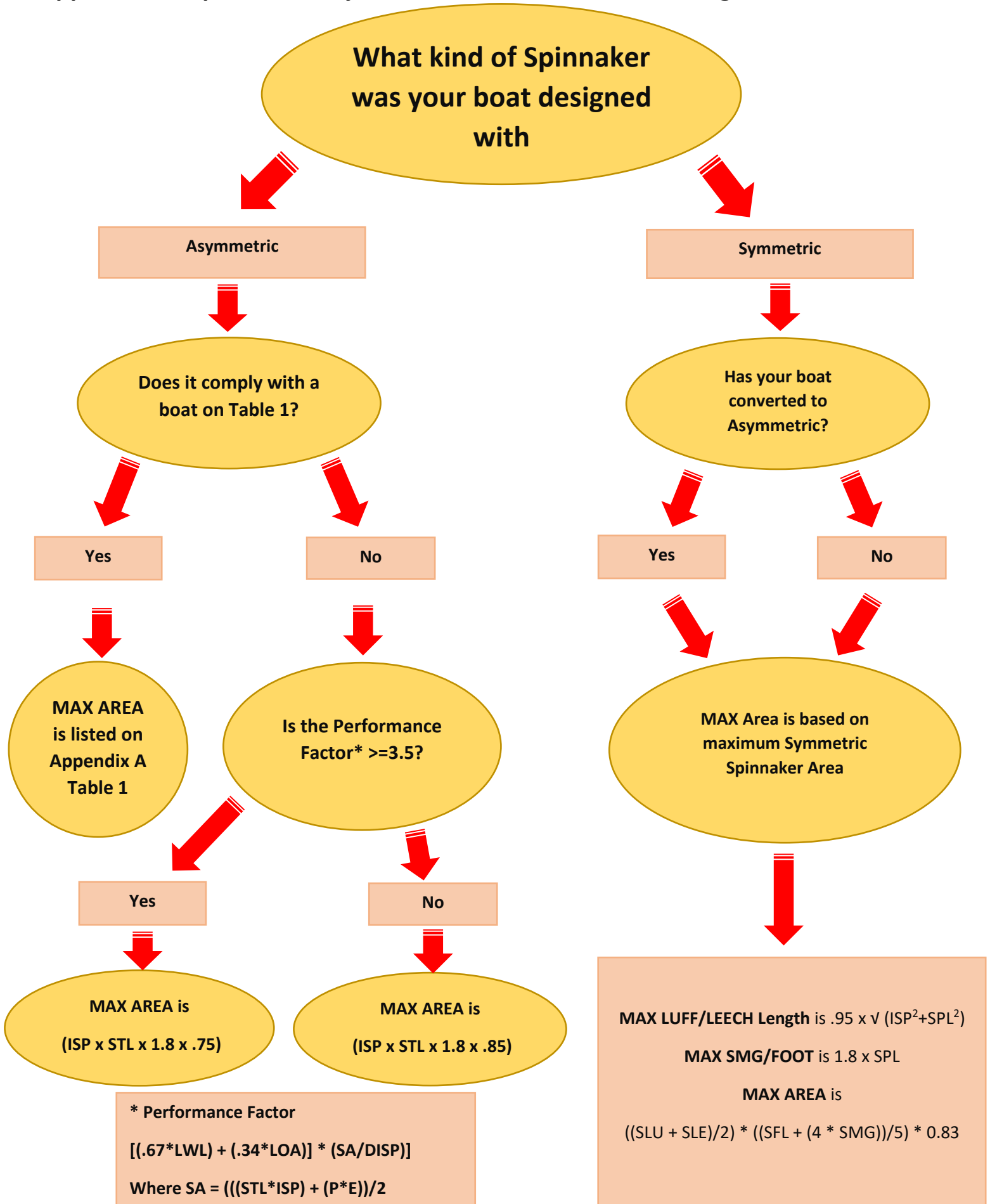

## Appendix B - Boats with Standard Asymmetrical Spinnaker Areas

This Table 1 is not meant to be all inclusive and may be updated as more data becomes available.

**TABLE 1**

BOAT	MAX AREA (SQ FT)	BOAT	MAX AREA (SQ FT)
<a href="#">1D 35</a>	1041.00	<a href="#">J-100</a>	861.00
<a href="#">Beneteau First 40.7</a>	1101.00	<a href="#">J-105</a>	957.90
<a href="#">C&amp;C 30 ODR</a>	1281.00	<a href="#">J-109</a>	1163.00
<a href="#">Club Swan 42</a>	1991.00	<a href="#">J-111</a>	1399.00
<a href="#">e33</a>	869.00	<a href="#">J-120</a>	1776.00
<a href="#">Etchells 22</a>	403.38	<a href="#">J-121</a>	1658.00
<a href="#">Farr 40</a>	1736.73	<a href="#">J-122</a>	1663.00
<a href="#">Farr/Mumm 30</a>	982.00	<a href="#">Melges 24</a>	601.00
<a href="#">Herreshoff S</a>	262.00	<a href="#">Melges 32</a>	1345.00
<a href="#">IC 37</a>	1607.42	<a href="#">Pearson Ensign</a>	311.00
<a href="#">J-22</a>	334.00	<a href="#">Rhodes 19</a>	268.89
<a href="#">J-70</a>	491.00	<a href="#">Soling</a>	416.00
<a href="#">J-80</a>	700.00	<a href="#">Watch Hill 15</a>	280.00
<a href="#">J-92</a>	1001.00	<a href="#">VX One</a>	282.00
<a href="#">J-92 S</a>	925.79		